

Overview

These are the recommended installation instructions for using Hydraway with edge drains. Please contact us for additional questions regarding your specific application.

Hydraway is trenched in along the sides of highways and other pavement edges to allow the underlying structural layers to drain and remain stable.

Installation

- Dig a 4-inch wide vertical trench to run the length of the edge where drainage is needed.
- For a highway edge drain, 12- or 18-inch Hydraway is installed to a depth so that the top of Hydraway is 6 inches above the invert of the bottom of the concrete (See Figure 1).
- For pavement edges such as driveways or parking lots, 6- or 12-inch Hydraway is installed to a depth so that the top of Hydraway is 4 to 6 inches above the invert of the bottom of the concrete (See Figure 2).
- Unroll and place Hydraway into the center of the vertical trench (See Figure 3).
- Install proper fittings and use HydraTape to ensure a solid connection (See Figure 4).

Determine Drainage Layout

Locate the area that requires drainage and create a slope to the point of discharge. The point of discharge can be a ditch, a catch basin, collector pipe or down a hillside.

Trench Backfill

Hydraway should be placed in the center of the trench with the backfill material placed on both sides of the drain lines. This is important to keep the fines from the surrounding soils contaminating the system. The trenches should be backfilled with “coarse” sand or fractured pea gravel. The sand should be clean, free-draining, well-graded and free of fine-grained soil particles. Refrain from using cement sand or playground sand. However, if coarse sand is not geographically available, use small “angular” gravel such as pea gravel.

Other considerations

Don't forget to locate and mark the utility lines.

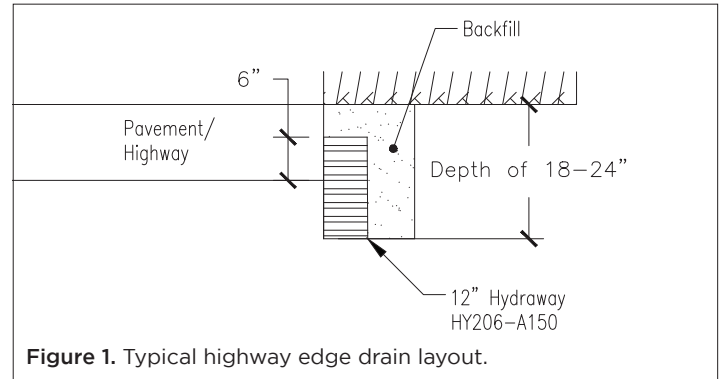

Figure 1. Typical highway edge drain layout.

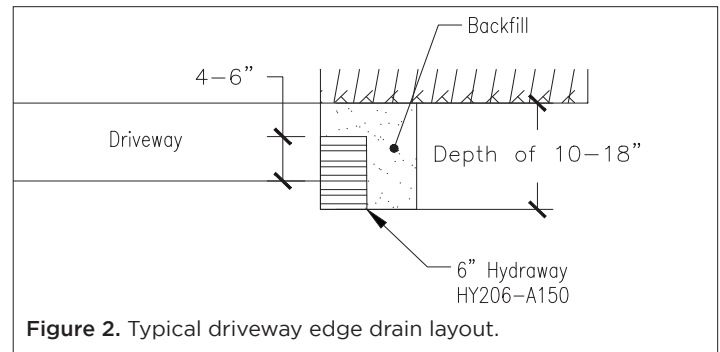

Figure 2. Typical driveway edge drain layout.

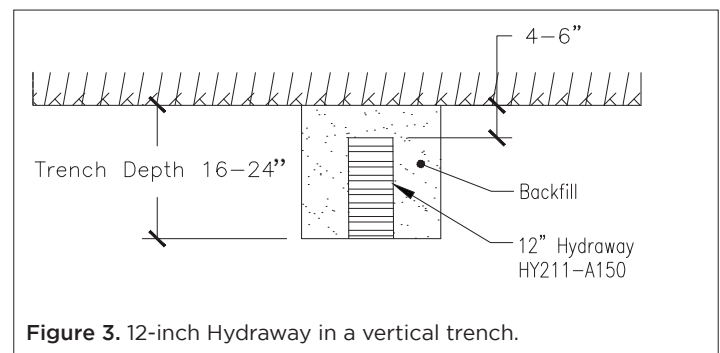

Figure 3. 12-inch Hydraway in a vertical trench.

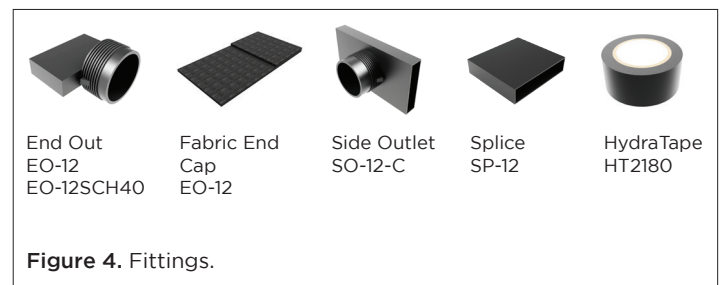

Figure 4. Fittings.